

400G/800G/1.6T DR

Description

The VLINK 400G/800G/1.6T DR product is assembled using the FA-MT method. It functions as the signal transmitter and receiver inside the optical module, and is a critical component of the 400G/800G/1.6T optical module.

Key Features

- High Market Demand
- High Degree of Automatic Assembly
- Low Cost

Applications

- 400G/800G/1.6T Data Center Application

Specifications

Parameter	Unit	Value
Wavelength	nm	1310 or 1550
Channel Count		4/8/16
Typ. Insertion Loss	dB	0.25
Max. Insertion Loss	dB	0.50
Max. Pitch Error	μm	0.75
Fiber Length Tolerance	%	± 0.2
Operating Temperature	°C	- 5 to + 70
Storage Temperature	°C	- 40 to + 85

Package Dimensions

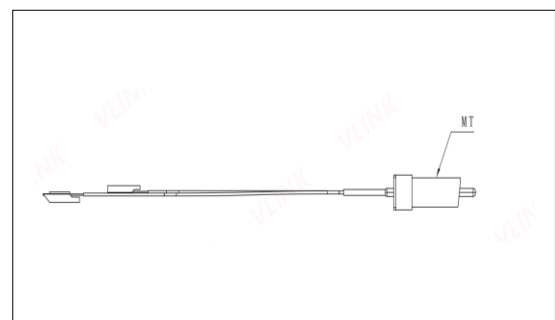
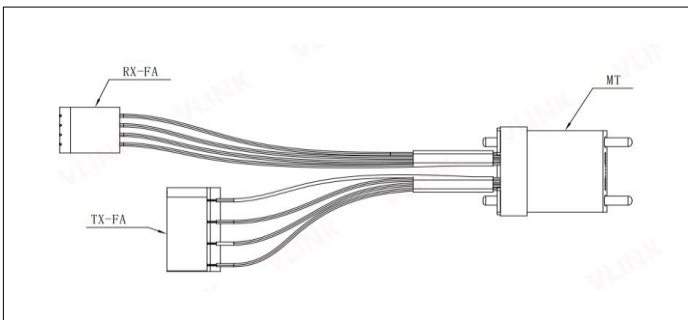

Ordering Information

①: Fiber Count

02 - 4 Channel

03 - 8 Channel

S - Specify

②: AR-Coating

NO - NO Coating

05 - R < 0.0 5% @ 1300 - 1320 nm

SS - Specify

③: Material Type

1 - Borosilicate

2 - Fused Silica

S - Specify

④: Port Spacing

1 - 127 μm

2 - 250 μm

3 - 500 μm

4 - 750 μm

S - Specify

⑤: Polishing Angle

0 - 0°

8 - 8°

S - Specify

⑥: Fiber Length

1 - 40 mm

S - Specify

⑦: Fiber Type

F - SM Fiber

S - Specify

⑧: FAU Thickness

1 - 0.7 mm

2 - 1.0 mm

S - Specify